

PAC Series Boost Meter

45mm

Figure 1.

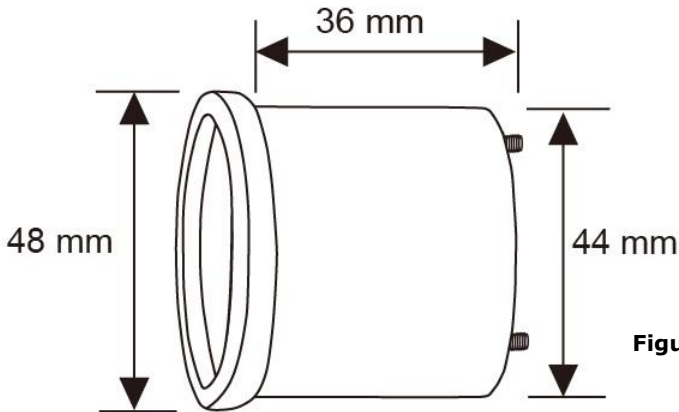
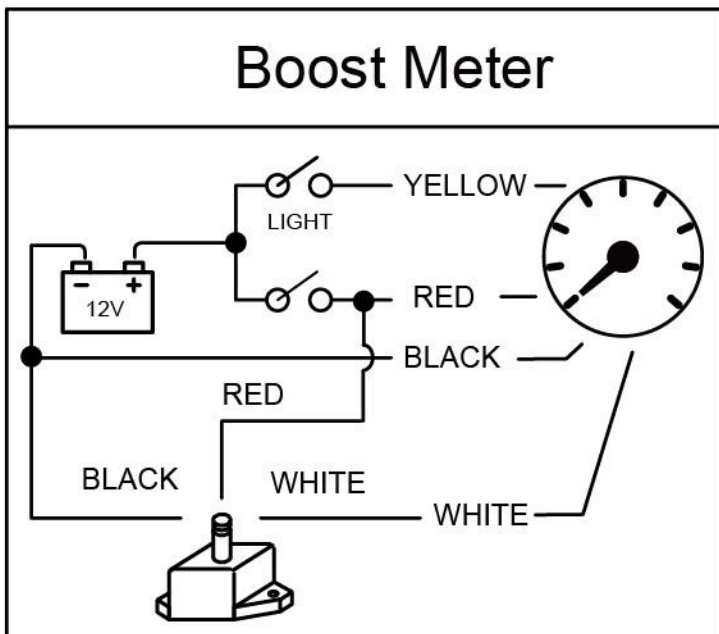

Figure 2.



Inside the box:

1. Boost meter x 1
2. Electrical boost sensor x 1
3. Manual x 1



Display range: 30inHg-0-30PSI

Supply voltage: 12VDC

1. The product is advised to be installed by a person specialising in the installation of such devices. If you wish to carry out the installation yourself, please read the following instructions carefully, or contact your supplier for assistance.
2. Before installation, please make sure that the vehicle is stationary; the engine is switched off and cool.
3. Choose the best mounting position for your particular vehicle. Do not mount the gauge in a position that will impair visibility or interfere with driving. Before drilling into the mounting surface, look for any hidden wiring or other components that could be damaged by the drill bit as it passes through. See **Figure 1.** for reference.
4. After mounting the gauge, please see the enclosed installation diagram. Caution : Incorrect connections can lead to short circuits. The cable must only be connected in accordance with the electrical terminal connection diagram. See **Figure 2.** for reference.
5. In case of any abnormal situation occurred, please ensure the sensor wire (if sensor is required) of the gauge is securely connected with ground terminal. Connect (Purple) to panel lights or parkers, circuit **+12V** power, to dim the light by 50%.

※ Technical details subject to change without notice.