

# DDG52V VOLTMETER

## Dual Display Voltmeter

This gauge is designed for measuring dual voltmeter in three digits of Blue LED display (**8-18V**), which helps to minimize the space for display and for easier monitoring the readouts. This gauge also features dim function in order to provide comfortable reading when head light is on.

**Figure 1.**

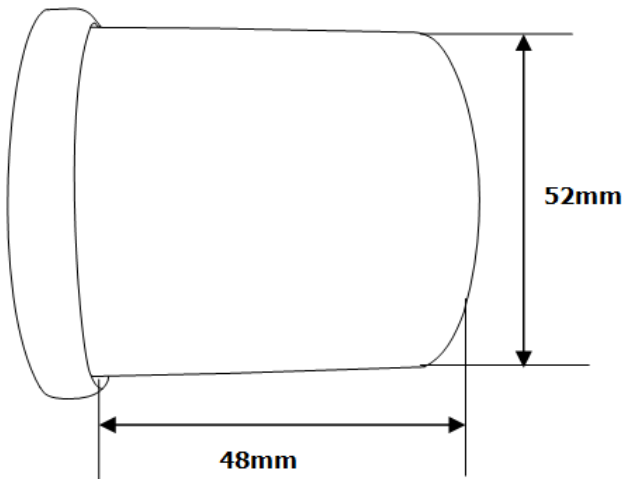

**Figure 2.**

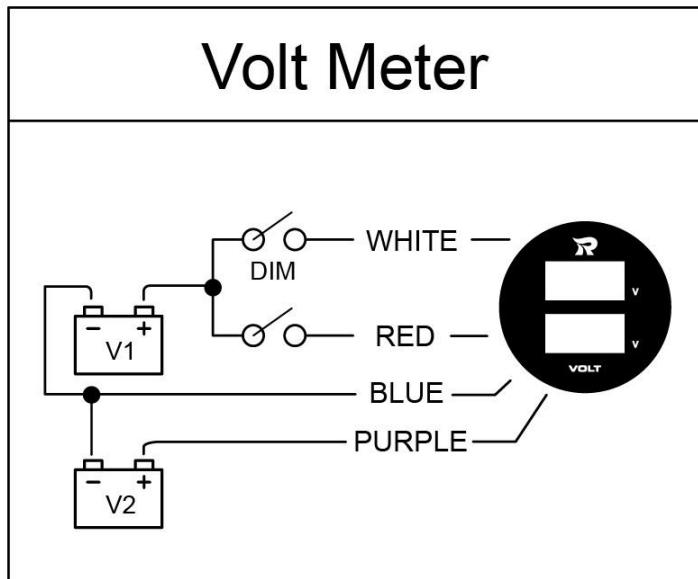

### Inside the box:

1. Voltmeter x 1
2. Manual x 1
3. Meter clamp x 1
4. Meter plug-in type wiring x 1



This product is designed for using **ONLY** on vehicles with 8-18V electrical system.



1. Before installation, please make sure that the vehicle is stationary; the engine is switched off and cool.
2. The product is advised to be installed by a person specialising in the installation of such devices. If you wish to carry out the installation yourself, please read the following instructions carefully, or contact your supplier for assistance.
3. Choose the best mounting position for your particular vehicle. Do not mount the gauge in a position that will impair visibility or interfere with driving. Before drilling into the mounting surface, look for any hidden wiring or other components that could be damaged by the drill bit as it passes through. Please see the enclosed diagram (**Figure 1.**) for reference.

### Installation:

1. After mounting the gauge, please see the enclosed installation diagram (**Figure 2.**).
2. Connect power (Red) wire (battery V1) and (Purple) wire (battery V2) respectively to a switched +12V power. Switch power means when key is on or run position.
3. Connect (Blue) wire to ground, negative (-) battery terminal or to a good chassis ground.
4. Connect (White) wire to panel lights; circuit +12V power, to dim the light by 50%.

※ Technical details subject to change without notice.