

DDG52WL WATER LEVEL METER

Dual Display Water Level Meter

This gauge is designed for measuring dual fuel level in three digits of Red LED display (**percentage %**), which helps to minimize the space for display and for easier monitoring the readouts. The two sets of fuel level sensors are included for easy installation (**Figure 2.**). This gauge also features dim function in order to provide comfortable reading when head light is on.

Figure 1.

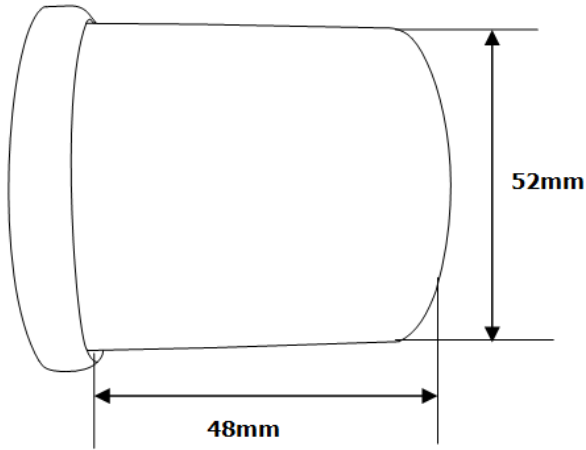

Inside the box:

- | | |
|---------------------------|---------------------------|
| 1. Fuel level meter x 1 | 3. Manual x 1 |
| 2. Fuel level sensors x 2 | 4. Meter clamp x 1 |
| | 5. Nut & ferrule pack x 1 |
- (sold separately)



This product is designed for using **ONLY** on vehicles with 12V electrical system.



1. Before installation, please make sure that the vehicle is stationary; the engine is switched off and cool.
2. The product is advised to be installed by a person specialising in the installation of such devices. If you wish to carry out the installation yourself, please read the following instructions carefully, or contact your supplier for assistance.
3. Choose the best mounting position for your particular vehicle. Do not mount the gauge in a position that will impair visibility or interfere with driving. Before drilling into the mounting surface, look for any hidden wiring or other components that could be damaged by the drill bit as it passes through. Please see the enclosed diagram (**Figure 1.**) for reference.

Figure 2.

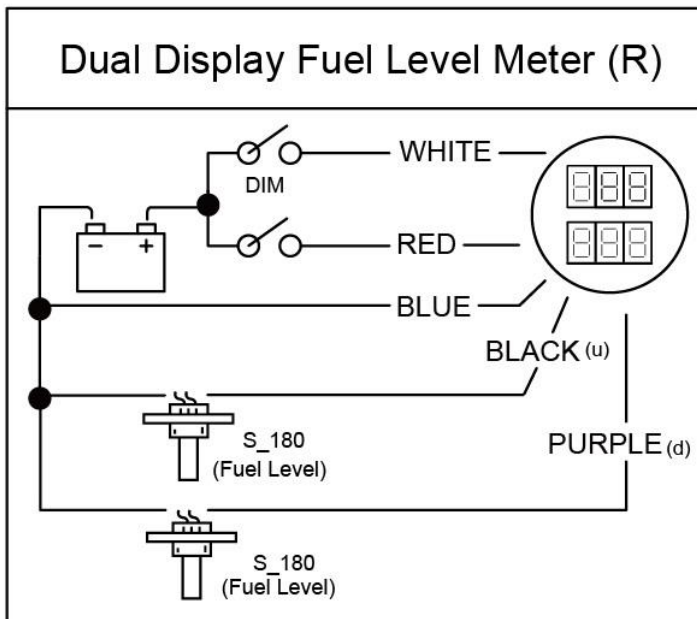

Installation:

1. After mounting the gauge, please see the enclosed installation diagram (**Figure 2.**).
2. Connect power (Red) wire to a switched +12V power. Switch power means when key is on or run position.
3. Connect (Blue) wire to ground, negative (-) battery terminal or to a good chassis ground.
4. Connect (White) wire to panel lights or parkers, circuit +12V power, to dim the light by 50%.
5. Connect two sensors wiring to upper (Black) wire and bottom (Purple) wire's location on rear of the gauge. **Note:** In case of any abnormal situation occurred, please ensure the sensor wire are securely connected into the rear of the meter. Please see the enclosed diagram (**Figure 2.**) for reference.

※ Technical details subject to change without notice.